

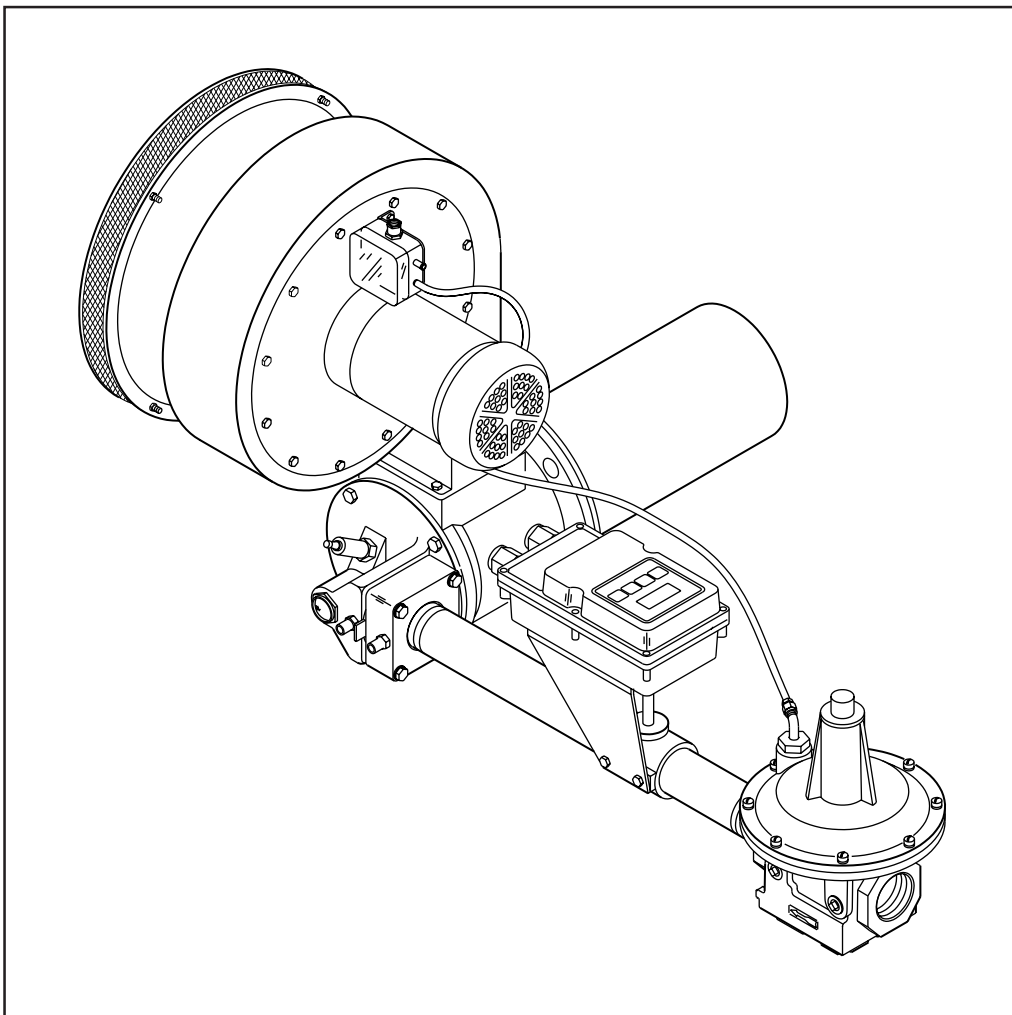

# ***Eclipse ThermAIR Burners***

***TA Series*** version 1.00



***Eclipse Combustion***

ISO 9001 Registered

## **COPYRIGHT**

Copyright 1998 by Eclipse Combustion, Inc. All rights reserved worldwide. This publication is protected by federal regulation and shall not be copied, distributed, transmitted, transcribed or translated into any human or computer language, in any form or by any means, to any third parties, without the express written consent of Eclipse Combustion, Inc., Rockford, Illinois, U.S.A.

## **DISCLAIMER NOTICE**

We reserve the right to change the construction and/or configuration of our products at any time without being obliged to adjust earlier supplies accordingly.

The material in this manual is believed adequate for the intended use of the product. If the product, or its individual modules or procedures, are used for purposes other than those specified herein, confirmation of their validity and suitability must be obtained. Eclipse Combustion, Inc. warrants that the material itself does not infringe any United States patents. No further warranty is expressed or implied.

We have made every effort to make this manual as accurate and complete as possible. Should you find errors or omissions, please bring them to our attention so that we may correct them. In this way we hope to improve our product documentation for the benefit of our customers. Please send your corrections and comments to our Documentation Manager.

## **LIABILITY AND WARRANTY**

It must be understood that Eclipse Combustion's liability for its products, whether due to breach of warranty, negligence, strict liability, or otherwise, is limited to the furnishing of such replacement parts and Eclipse Combustion will not be liable for any other injury, loss, damage or expenses, whether direct or consequential, including but not limited to loss of use, income of or damage to material arising in connection with the sale, installation, use of, inability to use or the repair or replacement of Eclipse Combustion's products.

Any operation expressly prohibited in this Guide, any adjustment, or assembly procedures not recommended or authorized in these instructions shall void the warranty.



# *About this manual*

## **AUDIENCE**

This manual has been written for people who are already familiar with all aspects of a nozzle-mix burner and its add-on components, also referred to as “the burner system.”

These aspects are:

- design/selection
- use
- maintenance.

The audience is expected to have had experience with this kind of equipment.

## **THERMAIR DOCUMENTS**

### **Design Guide No. 114**

- This document

### **ThermAir Data Sheets, Series 114**

- Available for individual TA models
- Required to complete design & selection

### **Installation Guide No. 114**

Used with Data Sheet to complete installation

### **ThermAir Price List No. 114**

Used to order burners

## **RELATED DOCUMENTS**

- EFE 825 (Combustion Engineering Guide)
- Eclipse Bulletins and Info Guides: 710, 732, 742, 760, 818, 832, 852, 854, 856, 610, 620, 630, 826, 820, 930, I-354.

### **Purpose**

The purpose of this manual is to ensure that the design of a safe, effective, and trouble-free combustion system is carried out.

## DOCUMENT CONVENTIONS

There are several special symbols in this document. You must know their meaning and importance.

The explanation of these symbols follows below. Please read it thoroughly.



### **Danger:**

---

**Indicates hazards or unsafe practices which **WILL** result in severe personal injury or even death. Only qualified and well trained personnel are allowed to carry out these instructions or procedures.**  
**Act with great care and follow the instructions.**

---



### **Warning:**

**Indicates hazards or unsafe practices which could result in severe personal injury or damage.**  
**Act with great care and follow the instructions.**



### **Caution:**

*Indicates hazards or unsafe practices which could result in damage to the machine or minor personal injury, Act carefully.*



### **Note:**

*Indicates an important part of the text. Read thoroughly.*

## HOW TO GET HELP

If you need help, contact your local Eclipse Combustion representative.



# *Table of contents*

	<b>About this manual</b> .....	3
	Audience .....	3
	ThermAir Documents .....	3
	Related Documents .....	3
	Document Conventions .....	4
	How to Get Help .....	4
	<b>Table of Contents</b> .....	5
<b>1</b>	<b>Introduction</b> .....	7
	Product Description .....	7
<b>2</b>	<b>Safety</b> .....	9
	Capabilities .....	10
	Operator Training .....	10
	Replacement Parts .....	10
<b>3</b>	<b>System Design</b> .....	11
	Burner Option Selection .....	12
	Blower Option Selection .....	14
	Control Methodology .....	15
	Ignition System .....	18
	Flame Monitoring Control System .....	18
	Main Gas Shut-Off Valve Train .....	19
	<b>Appendix</b> .....	20
	Conversion Factors .....	20
	Key To System Schematics .....	21



# Introduction

# 1

## PRODUCT DESCRIPTION

The ThermAir burner (TA Series) is a nozzle-mix burner with a packaged combustion air blower that is designed to fire with fixed combustion air over a wide gas turndown range. An integral gas orifice is provided to ease burner setup. The burner is designed to facilitate:

- fixed air operation
- direct spark ignition
- simple gas control
- multiple fuel capability

The burner is suitable for direct and indirect air heating for a wide range of applications on industrial furnaces and ovens.

**Figure 1.1**      **ThermAir Burner**

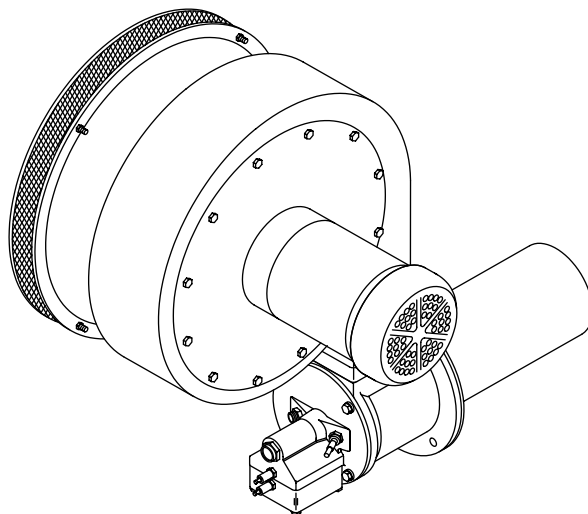







# 2

## INTRODUCTION

## SAFETY

This section is provided as a guide for the safe operation of the ThermAir burner system. All involved personnel should read this section carefully before operating this system.



### **Danger:**

---

**The ThermAir burners, described herein, are designed to mix fuel with air and burn the resulting mixture. All fuel burning devices are capable of producing fires and explosions if improperly applied, installed, adjusted, controlled, or maintained.**

**Do not bypass any safety feature; fire or explosion could result.**

**Never try to light a burner if it shows signs of damage or malfunction.**

---



### Warning:

*The burner might have HOT surfaces. Always wear protective clothing when approaching the burner.*



### Note:

*This manual provides information in the use of these burners for their specific design purpose. Do not deviate from any instructions or application limits described herein without written advice from Eclipse Combustion.*

*Read the entire manual before attempting to start this system. If you do not understand any part of the information contained in this manual, contact your local Eclipse representative or Eclipse Combustion before continuing.*

## **CAPABILITIES**

Only qualified personnel, with good mechanical aptitude and experience on combustion equipment, should adjust, maintain, or troubleshoot any mechanical or electrical part of this system.

## **OPERATOR TRAINING**

The best safety precaution is an alert and trained operator. Train new operators thoroughly and have them demonstrate an adequate understanding of the equipment and its operation. A regular retraining schedule should be administered to ensure operators maintain a high degree of proficiency.

## **REPLACEMENT PARTS**

Order replacement parts from Eclipse Combustion only. All Eclipse Combustion approved, customer supplied valves or switches should carry UL, FM, CSA, CGA, and/or CE approval, where applicable.



# *System Design*

# 3

## DESIGN

### Design structure

The design process is divided into the following steps:

**1. Burner Option Selection including:**

- Burner Model / Size Selection
- Fuel Type
- Air Supply
- Combustor
- Burner Configuration
- Control Motor
- Gas Control Options
- Flame Supervision
- Air Flow Switch

**2. Blower Option Selection including:**

- Power Supply Frequency
- Pressure & Flow
- Blower Motor Type
- Blower Inlet
- Motor Orientation

**3. Control Methodology including:**

- Burner Control
- Trial for Ignition

**4. Ignition System including:**

- Ignition Transformer

**5. Flame Monitoring Control System including:**

- Flame Sensor
- Flame Monitoring Control

**6. Main Gas Shut-Off Valve Train including:**

- Component Selection
- Valve Train Size

## Step I: Burner Option Selection

Step I describes how to select burner options to suit an application. Use the ThermAir Price List 114 and Data Sheets, Series 114 when following this selection process.

Caution:

Consult EFE-825, Eclipse Combustion Engineering Guide, or contact Eclipse Combustion if you have special conditions or questions.

### Burner Model / Size Selection

Consider the following when selecting the burner size:

- **Heat Input.** Calculate the required heat input to achieve the required heat balance.
- **Power Supply Frequency.** Burner capability to fire against elevated chamber pressures will be affected by the power supply frequency (50Hz or 60Hz power).
- **Combustion Chamber Pressure.** Consider the effects that large or varying chamber pressures have on burner performance.
- **Altitude.** The maximum burner capacity is reduced by approximately 3% each 1000 feet (300 meters) above sea level.
- **Combustion Air Supply.** Combustion air should be fresh (20.9% O<sub>2</sub>) and clean (without corrosives).
- **Combustion Air Temperature.** Higher air supply temperatures will reduce the burner maximum capacity. Contact Eclipse for maximum capacities at elevated combustion air temperatures. The combustion air supply temperature should not exceed 250° F into the blower.
- **Fuel Type.** Variation in calorific value and density will affect burner performance.

### Fuel Type

Fuel	Symbol	Gross Heating Value	Specific Gravity
Natural gas	CH <sub>4</sub> 90%+	1000 BTU/ft <sup>3</sup> (40 MJ/m <sup>3</sup> )	0.60
Propane	C <sub>3</sub> H <sub>8</sub>	2570 BTU/ft <sup>3</sup> (103 MJ/m <sup>3</sup> )	1.52
Butane	C <sub>4</sub> H <sub>10</sub>	3250 BTU/ft <sup>3</sup> (130 MJ/m <sup>3</sup> )	1.95

BTU/ft<sup>3</sup> @ standard conditions (MJ/m<sup>3</sup> @ normal conditions)

If using an alternative fuel supply, contact Eclipse Combustion with an accurate breakdown of the fuel components.

### Air Supply

When a standard ThermAir burner is ordered, a combustion air blower is supplied and mounted directly to the burner body.

### Combustor Type

All ThermAir burners come equipped with 310SS combustors for applications up to 1500°F (815°C). For higher temperature applications, consult factory.

## Burner Configurations

### Upright

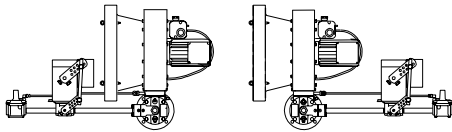

Left Hand Piping

Right Hand Piping

### Inverted

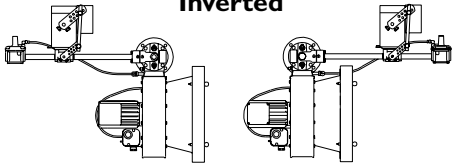

Left Hand Piping

Right Hand Piping

## Gas Control Options

COMPLETE  
(ratio regulator  
and control BV)

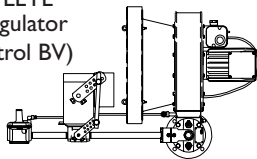

BASIC  
(control BV only)

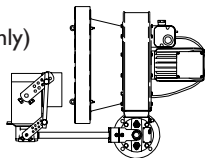

STRIPPED  
(Less ratio regulator  
and control BV)

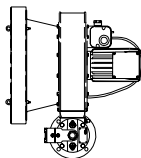

## Control Motor (Applies to Basic and Complete Configurations)

Select a control motor. Standard control motor options include various models which Eclipse will mount to the gas control valve. ThermAirs can be ordered with control motor bracket and mounting hardware only. Customer supplied control motors must conform to the these specifications:

- rotation not to exceed 2 rpm.
- minimum torque of 25 in-lb. (2,8 Nm)
- 90° stroke.
- continuous modulating or high/low modulating control.
- reversible direction of rotation.
- certain applications may require control motors with a limit switch or switches if:
  - the burner capacity is to be limited to fit an application.
  - the chamber is to be fired with positive or negative pressure.
  - the chamber pressure is outside the range -1" w.c. to +1" w.c. (-2,5 to 2,5 mbar)
  - there is a need to indicate a high and/or low fire gas butterfly valve (BV) position.

## Burner Configuration

Select configuration.

## Gas Control Options

Select the gas pipe thread type and the gas control options desired. Gas control options are:

- Stripped, N.P.T. or Rc connections
- Basic, Modulating gas control valve (N.P.T. or Rc)
- Complete, Modulating gas control valve and ratio regulator

## Flame Supervision

Select a flame rod or "No Sensor Included" option. If a flame rod is selected, it will be factory mounted in the burner. If "No Sensor Included" option is selected, a U.V. scanner must be ordered separately. Flame rods are available for all ThermAir Burners up to and including the TA100. Larger burners must be monitored with a U.V. scanner.



### Note:

Access for the installation of certain UV scanners can be limited with specific piping arrangements on certain size burners. Access is restricted by the blower housing scroll and the orientation of the 1/2" NPT UV scanner port on the burner's rear cover.

Verify that the UV scanner model you have selected is able to be installed on the burner in your desired burner configuration.

## Step 1: Burner Option Selection (continued)

## Step 2: Blower Option Selection

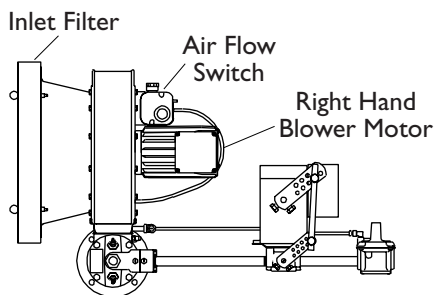

### Air Flow Switch

The air flow switch provides a signal to the monitoring system when there is not enough air pressure from the blower. If a switch is selected, it will be factory mounted.



#### Warning:

**Eclipse Combustion supports the NFPA regulation requiring, as a minimum standard for main gas shut-off systems, the use of an air pressure switch in conjunction with other system components.**



#### Note:

*Standard blower options are listed in Price List 114, additional blower options are available through Eclipse Combustion. Price and leadtime may vary.*

### Power Supply Frequency

Select the 50Hz or 60Hz option. The 50Hz blower motors have IEC frames and are CE marked. The 60Hz motors have NEMA frames.

### Pressure & Flow

ThermAirs include a combustion air blower.

### Blower Motor Type

Motor types include various options: voltages, single or three phase, TEFC or automotive duty enclosures.

### Blower Inlet

When selecting an inlet, consider the following:

- amount and size of particles in the air.
- sound requirements.
- space limitations.
- cleanliness requirements of the process.

### Motor Orientation

All ThermAirs are assembled with either a right-hand or left-hand blower motor orientation.

### Step 3: Control Methodology

#### Gas Turndown

The entire ThermAir burner family is capable of gas turndown of greater than 30:1 based upon starting at high fire. A typical single burner installation would be controlled by a modulating gas valve. Leakage flow through this valve in the closed position could exceed the desired low fire input. If this is the case, consider an alternate control method to obtain your desired low fire.

#### Control Methods

There are numerous gas control options possible to provide a reliable gas control/ignition system. The method of control you select and the type of “Gas Control Options” you select will have a large impact on burner performance and ignition reliability. These options and their variations are outlined in the following schematics.

#### With Ratio-Regulator

A ThermAir burner equipped with a packaged blower and a ratio-regulator is ignited via direct spark at low fire.

##### 1. Air

Air flow to the burner is fixed.

##### 2. Gas

High fire gas flow is limited by a metering gas orifice, sized for a given loading line pressure to the ratio-regulator, installed in the burner at the gas inlet. Gas flow to the burner is controlled by the modulating gas valve in the gas line. Although the Ratio-Regulator does not control gas flow, it will provide for ease of burner set-up and additional safety if there is reduced combustion air pressure and/or flow.

**Figure 3.1** *Packaged blower with ratio-regulator*

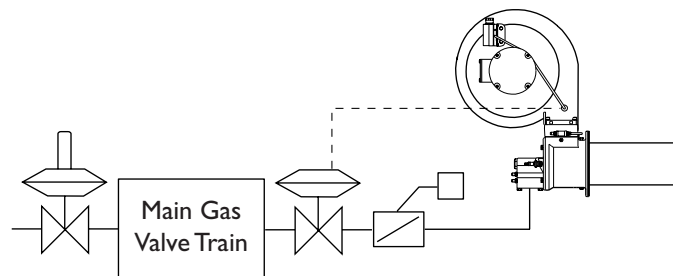

## Without Ratio-Regulator

Refer to “Packaged Blower Burner Adjustment” in ThermAir Installation Guide for Start and Stop Adjustment instructions.

### 1. Air

Air flow to the burner is fixed.

### 2. Gas

High fire gas flow of a ThermAir burner not equipped with a ratio-regulator is controlled by the outlet pressure of the main gas pressure regulator. The main gas pressure regulator must be adjusted to change high fire gas flow (ref: Figure 3.2).

**Figure 3.2 Packaged blower without ratio-regulator**

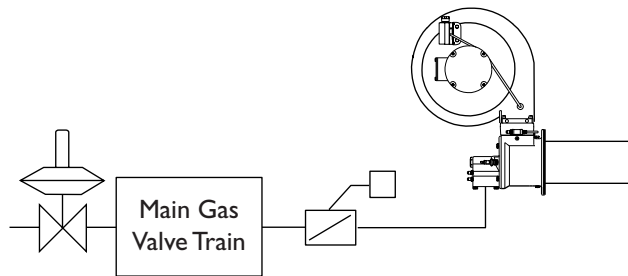

## The Use of Blocking Valves



### Note:

The position of the gas blocking valve(s) relative to the ratio-regulator will have an impact on burner performance.

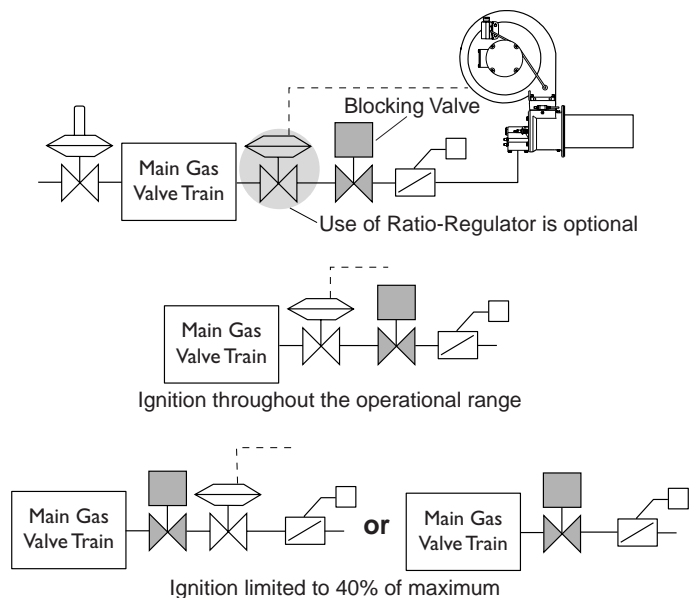

## Trial for Ignition

It is recommended that low fire start be used. Local safety and insurance codes require limits on the maximum trial for ignition period. These limits vary from one location to the next. Ensure that you are in compliance with the strictest requirement applicable to your installation.



The time it takes for a burner to ignite depends upon:

- the distance from the gas shut-off valve to the burner
- the gas flow at start conditions

It is possible to have low fire too low to ignite the burner within the trial for ignition period. Under these circumstances you must consider one of the following options:

- start at a higher input level
- resize and/or relocate the gas controls
- use bypass start gas

### **Bypass Start Gas (Optional)**

A bypass start gas circuit provides gas flow around gas control valves during the trial for ignition period. Bypass start gas may be required if the automatic gas control valves are not located close to the burner.

The solenoid valve in the bypass line plus the automatic gas shut-off valves are opened during the trial for ignition period. If a flame is established, the bypass solenoid closes at the end of the trial for ignition period while the automatic gas control valves remain open. If a flame is not established, then both the bypass solenoid and the automatic shut-off valves close.

### **Bypass start gas circuit schematics**

Key points to consider when providing bypass start gas for ignition.

1. Locate the bypass solenoid valve as close to the burner as possible.
2. Provide some means for flow adjustment.
3. To provide the bypass start gas circuit with a constant gas pressure:
  - A. Connect to the main gas line downstream of the main gas pressure regulator (see Figure 3.3).
  - B. Provide a bypass gas pressure regulator (see Figure 3.4)
4. The downstream gas connection can be either through the peepsight location in the rearcover or into the main gas line to the burner.

**Figure 3.3 Bypass gas pressure regulated via main gas pressure regulator.**

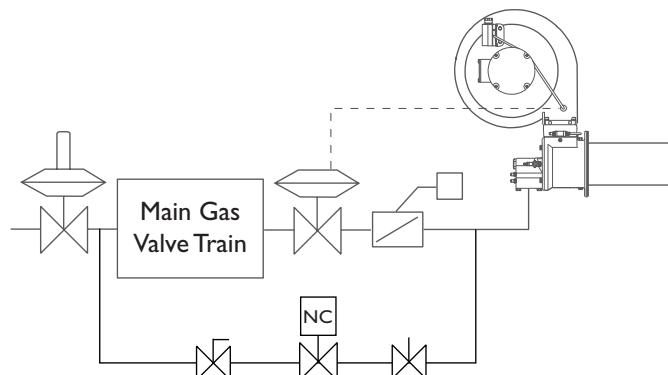
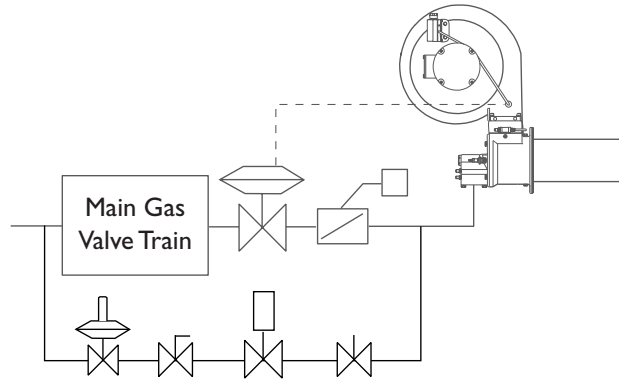

Figure 3.4

**Bypass gas pressure regulated via independent pressure regulator.**



#### Step 4: Ignition System

#### Ignition Transformer

For the ignition system, use a transformer with:

- secondary voltage 6,000 to 8,000 VAC.
- minimum secondary current 0.02 amps continuous.
- full wave output.

**DO NOT USE** the following:

- twin outlet transformer
- distributor type transformer
- half wave transformer
- high voltage >8,000VAC
- low voltage <6,000VAC

#### Step 5: Flame Monitoring Control System

The flame monitoring control system consists of two main components:

- Flame Sensor
- Flame Monitoring Control

#### Flame Sensor

Two types can be used on ThermAir Burners:

- flame rod
- U.V. scanner

Flame rods are available for ThermAir Burner sizes TA015 through TA100. Further information can be found in:

- Info Guide 832

U.V. scanners can be used on all ThermAir Burner sizes. Further information can be found in:

- Info Guide 852; 90° U.V. scanner
- Info Guide 854; straight U.V. scanner
- Info Guide 856; self-check U.V. scanner

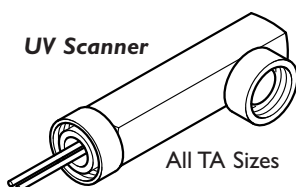
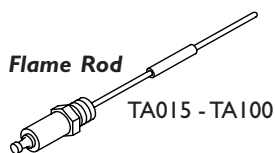

## Step 6: Main Gas Shut-Off Valve Train

### Flame Monitoring Control

The Flame Monitoring Control processes the signal from the flame rod, or U.V. scanner, and controls the start-up sequence and the main gas shut-off valve sequence.

Eclipse Combustion recommends the use of flame monitoring control systems which maintain a spark for the entire trial for ignition period when using U.V. scanners. Some of these flame monitoring models are:

- Veri-Flame; see Bulletin / Info Guide 610, 620, 630
- Bi-Flame series; see Instruction Manual 826
- Multi-Flame series 6000; see Instruction Manual 820

#### DO NOT USE:

- PCI Automatic flame monitoring
- Honeywell RM7890 series flame monitoring
- Flame monitoring relays which interrupt the trial for ignition when the flame is detected.

### Component Selection

Eclipse Combustion can help in the design of a main gas shut-off valve train that satisfies the customer and complies with all local safety standards and codes set by the authorities within that jurisdiction. Contact Eclipse Combustion for further information.



#### Note:

*Eclipse Combustion supports NFPA regulations (two gas shut-off valves as a minimum standard for main gas shut-off systems).*

### Valve Train Size

Fuel pressure supplied to the ratio regulator inlet (when used) must be at least 15" w.c. (37.5mbar). It should not exceed the maximum pressure rating of the ratio-regulator. The valve train should be sized sufficiently to provide the specified pressure.



#### Warning:

**Do not operate ThermAirs with gas inlet pressure less than the loading line pressure. Lower gas inlet pressures may cause the ratio regulator to remain fully open with reduced air flow. This could result in the possible accumulation of unburned fuel in the burner which, in extreme situations, could cause a fire or an explosion.**



# Appendix

## CONVERSION FACTORS

### Metric to English.

From	To	Multiply By
cubic meter (m <sup>3</sup> )	cubic foot (ft <sup>3</sup> )	35.31
cubic meter/hour (m <sup>3</sup> /h)	cubic foot/hour (cfh)	35.31
degrees Celsius (°C)	degrees Fahrenheit (°F)	(°C × 1.8) + 32
kilogram (kg)	pound (lb)	2.205
kilowatt (kW)	BTU/hr	3414
meter (m)	foot (ft)	3.28
millibar (mbar)	inches water column ("w.c.)	0.401
millibar (mbar)	pounds/sq in (psi)	14.5 × 10 <sup>-3</sup>
millimeter (mm)	inch (in)	3.94 × 10 <sup>-2</sup>
MJ/m <sup>3</sup> (normal)	BTU/ft <sup>3</sup> (standard)	2.491 × 10 <sup>-2</sup>

### Metric to Metric.







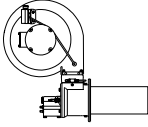

kiloPascals (kPa)	millibar (mbar)	10
meter (m)	millimeter (mm)	1000
millibar (mbar)	kiloPascals (kPa)	0.1
millimeter (mm)	meter (m)	0.001

### English to Metric.

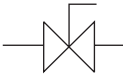
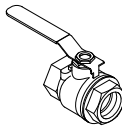
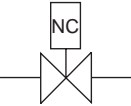
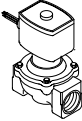
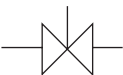
From	To	Multiply By
BTU/hr	kilowatt (kW)	0.293 × 10 <sup>-3</sup>
cubic foot (ft <sup>3</sup> )	cubic meter (m <sup>3</sup> )	2.832 × 10 <sup>-2</sup>
degrees Fahrenheit (°F)	degrees Celsius (°C)	(°F – 32) ÷ 1.8
foot (ft)	meter (m)	0.3048
inches (in)	millimeter (mm)	25.4
inches water column ("wc)	millibar (mbar)	2.49
pound (lb)	kilogram (kg)	0.454
pounds/sq in (psi)	millibar (mbar)	68.95
BTU/ft <sup>3</sup> (standard)	MJ/m <sup>3</sup> (normal)	40.14

## KEY TO SYSTEM SCHEMATICS

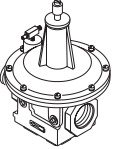
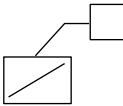
These are the symbols used in the schematics.

Symbol	Appearance	Name	Remarks	Bulletin/ Info Guide
		ThermAir		
		Main Gas Shutoff Valve Train	Eclipse Combustion, Inc. strongly endorses NFPA as a minimum	756
		Gas Cock	Gas cocks are used to manually shut off the gas supply on both sides of the main gas shut-off valve train.	710
		Solenoid Valve (normally closed)	Solenoid valves are used to automatically shut off the gas supply on a bypass gas system or on small capacity burners.	760
		Adjustable Limiting Orifice	Adjustable limiting orifices are used for fine adjustment of gas flow.	730
		Pressure Regulator	A pressure regulator reduces gas pressure to a stable, usable pressure.	684
		Ratio Regulator	The ratio regulator adjusts the gas flow in ratio with the air flow. It controls the outlet pressure equal to the impulse line pressure. The impulse line is connected between the top of the ratio regulator and the blower housing.	742
		Automatic Gas Control Valve	An automatic gas control valve adjusts gas flow to the burner based on control system requirements.	720
		Impulse Line		



**Offered By:**

Power Equipment Company  
2011 Williamsburg Road  
Richmond, Virginia 23231  
Phone (804) 236-3800  
Fax (804) 236-3882

---

[www.peconet.com](http://www.peconet.com)